

# Studying at ETH Zürich

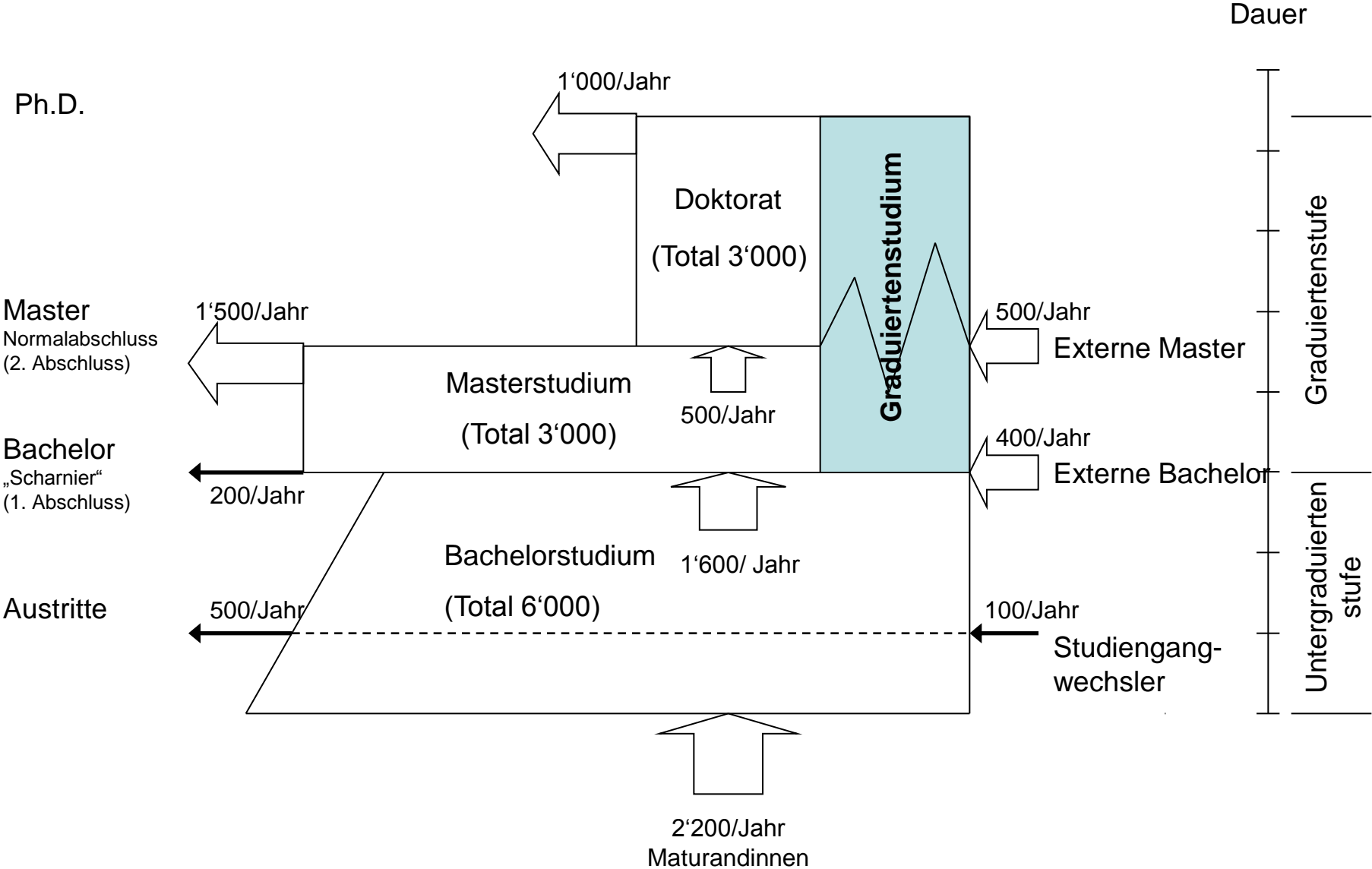

# Stellung des Graduiertenkollegs innerhalb der Graduiertenstufe

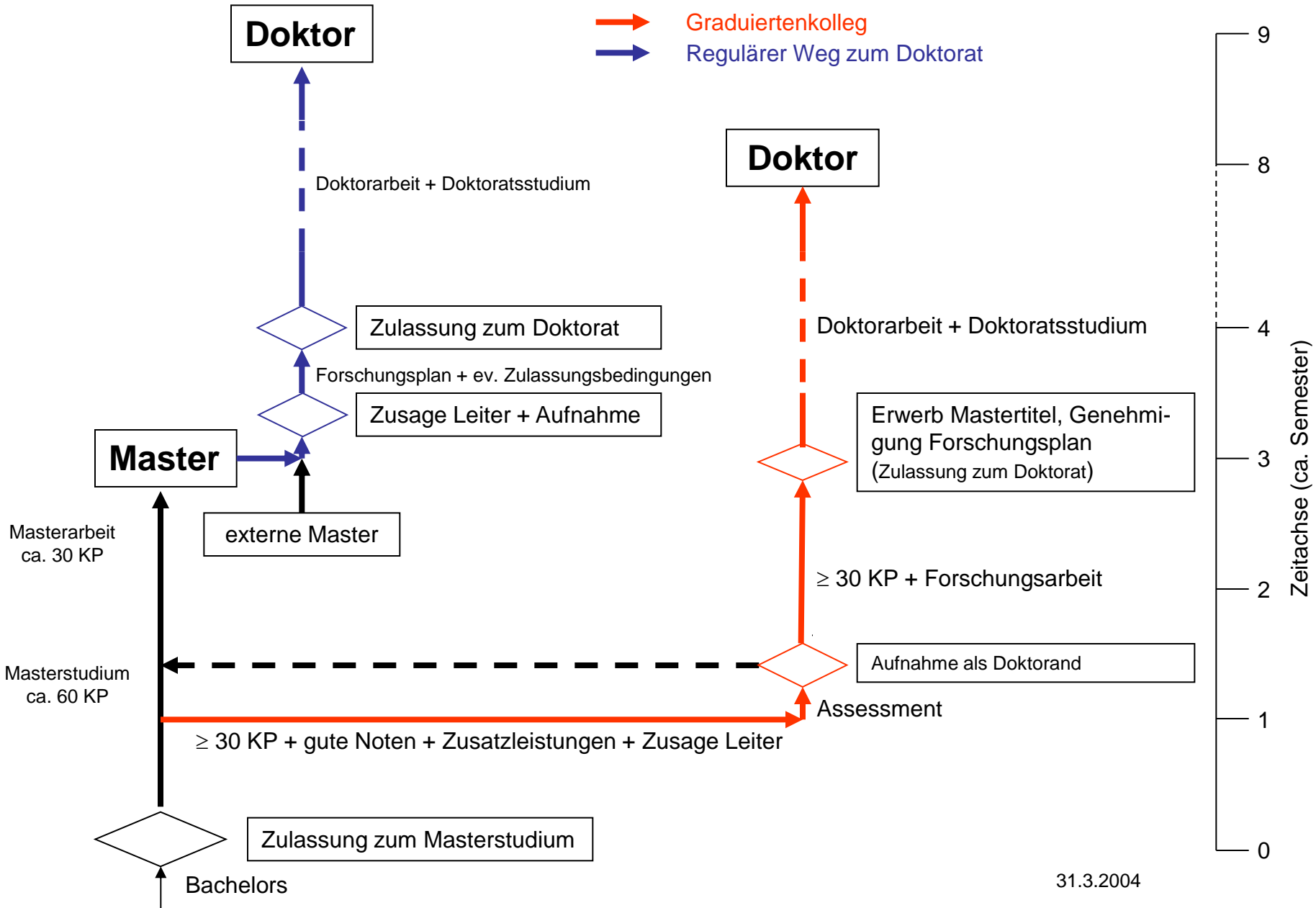

## IDEA League: 9 Quality Management Principles

1. Existence of an evaluation scheme to review and monitor the quality of the study programmes.
2. One person is responsible for the design and delivery of each study programme, he/she is assisted by a committee.
3. Qualification profile for each study programme, clearly defining the aims and objectives of the programme.
4. Students are involved in the feedback loops both for the overall curriculum and for individual courses.
5. Consideration of the views of alumni is part of the feedback process.
6. Fundamental structural changes of a curriculum are discussed within the IDEA League.

## IDEA League: 9 QM Principles (II)

7. Experts from IDEA universities are invited to participate in quality evaluations organised by each of the partner universities.
8. The appointment of professors with a high international standing in research is crucial to the aim of educating students in a research environment, especially in providing an international dimension.
9. IDEA respects the national conditions for entrance into universities but recognises the advantages of recruiting students with motivation and high academic ability. Admission of students to graduate programmes should be selective in order to ensure quality of the outcome.